

Vacuum Packaging Machine

Advanced Control System

(ACS)

Dealer Manual

Art No. 0894770

Original Instructions for Use

© Henkelman 2017-2021

Copyright © Henkelman BV 2017-2021

Henkelman BV reserves the right to change specifications and/or spare parts without prior notice.

The content of this dealer manual may also be changed without prior notice.

For information about settings, maintenance and repairs not provided for in this dealer manual, please contact the technical department of your supplier.

Henkelman BV accepts no liability for damage and/or problems arising from the use of spare parts not supplied by Henkelman BV.

This dealer manual has been compiled with all possible care. Henkelman BV assumes no responsibility for any errors in this manual and/or the consequences of an erroneous interpretation of the instructions.

All rights reserved. No part of this publication may be reproduced, stored in computerised databases, or made public, in any form or by any means, either electronic, mechanical, through photocopying, recording or otherwise, without the prior written consent of Henkelman BV. This also applies to the associated drawings and diagrams.

Contents

List of Figures.....	5
1 Preamble.....	6
1.1 List of the Symbols Used in this Manual.....	6
1.2 Qualified personnel.....	6
1.3 Terms and abbreviations.....	7
2 Advanced Control System (ACS).....	8
2.1 Operating Elements.....	8
2.2 Proceeding to the Next Step in the Cycle.....	9
2.3 Changing the ACS Settings.....	9
3 Installation.....	14
3.1 Transportation and Installation.....	14
3.2 Connecting the Machine.....	14
3.3 Prior to the First Use.....	16
3.4 Removing the Front Panel.....	16
3.5 Gas.....	17
3.6 Gas+ (optional).....	18
3.7 Pre-seal and After-seal Settings.....	19
3.8 Sleeper settings.....	19
4 Maintenance.....	21
4.1 Changing the Program Settings.....	21
4.2 Dealer Information.....	22
4.3 Machine Counter.....	22
4.4 Setting Service Hour Counter.....	23
4.5 Pump Cleaning Message.....	24
4.6 Decrease the Cycle Time.....	24
4.7 Maintenance Schedule.....	25
5 Troubleshooting and Error Codes.....	27
5.1 Using Output Test.....	30
5.2 Checking Functioning of Individual Components.....	31
5.3 Resetting Factory Settings.....	33
5.4 Calibrating the Sensor.....	34
6 Appendices.....	35
6.1 Technical Data.....	35
6.1.1 Marlin series.....	35
6.1.2 Falcon series.....	36
6.1.3 Polar series.....	37
6.1.4 Boxer series.....	39
6.1.5 Lynx series.....	41

6.1.6 Toucan series.....42
6.1.7 Atmoz series.....43
6.2 Electrical Installation.....44
6.3 Logbook.....48

List of Figures

Figure 1: Control Panel of the Advanced Control System (ACS).....	8
Figure 2: Possible Display Modes.....	9
Figure 3: Possible Display Modes.....	9
Figure 4: Overview of the Settings menu.....	11
Figure 5: Overview of the Hardware menu.....	12
Figure 6: Overview of the Service menu.....	12
Figure 7: Overview of the Import/Export menu.....	13
Figure 8: Direction of Rotation of the Vacuum Pump.....	15
Figure 9: Hose connection for compressed air.....	16
Figure 10: Opening Front Panel floor models.....	17
Figure 11: Opening Front Panel table-top models.....	17
Figure 12: Screen shot of the navigation mode and the operating buttons of the ACS.....	21
Figure 13: Overview of the Electrical Installation.....	44
Figure 14: Overview of the Electrical Installation, Marlin.....	45
Figure 15: Overview of the Electrical Installation,.....	46
Figure 16: Overview of the Electrical Installation.....	47

1 Preamble

In this manual you will find exclusive information for our distributors about the Advanced Control System (ACS). You can find the general information about our machines in the user manual that is delivered with the machine.

You can download all our manuals from our website: www.henkelman.com. There you can also find information and videos about the maintenance and programming of our machines.

Feel free to contact us with your questions by email at info@henkelman.com or by phone on number +31 (0)73 621 3671.

1.1 List of the Symbols Used in this Manual

For all operations in which the safety of the operator and/or technician is at stake and where caution should be exercised, the following symbols are used.



Indicates a hazardous situation that, if not avoided, could result in serious injury or death and possibly material damage if one does not obey the safety instructions.



Indicates a hazardous situation that, if not avoided, could result in minor or moderate injury and possibly material damage if one does not follow the safety instructions.



Provides additional information that is helpful to do a task or to avoid problems.



This symbol warns for high voltage.

1.2 Qualified personnel

This document is intended for qualified personnel.



The term "qualified personnel" is defined here as individuals who thoroughly understand the equipment and its safe installation, operation or maintenance. Qualified personnel are physically capable of performing the required tasks, are familiar with all relevant and local safety rules and regulations and have been trained to safely install, operate or maintain the equipment. It is the responsibility of the company installing, operating or maintaining this equipment to ensure that its personnel meet these requirements.

1.3 Terms and abbreviations

ACS	Advanced Control System
Machine	Vacuum Packaging Machine
Pump	Vacuum pump

2 Advanced Control System (ACS)

The ACS is more than a control system. It includes unique features, special options and intelligent functions that add significant value to your vacuum packaging operations.

2.1 Operating Elements

The ACS control panel allows the machine to be operated and programs to be changed.

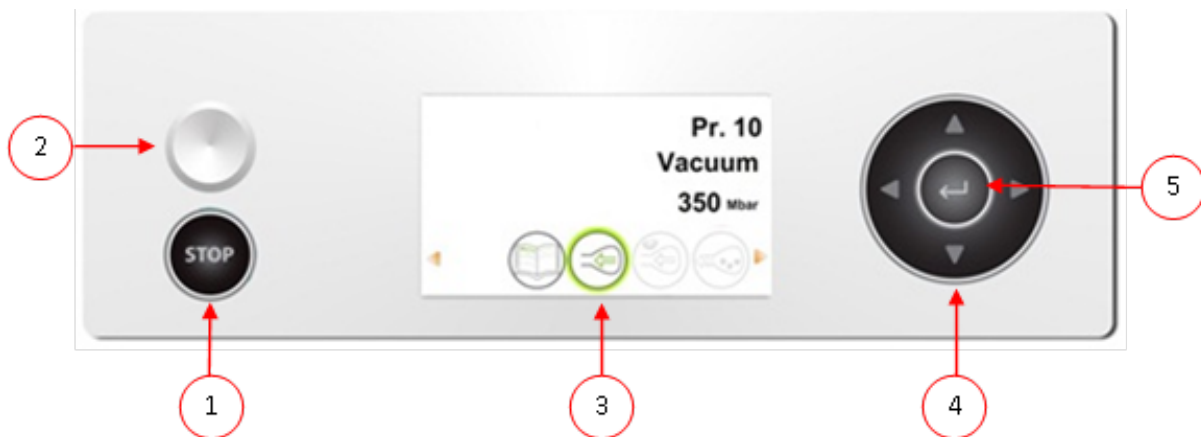

Figure 1: Control Panel of the Advanced Control System (ACS)

1. STOP button

This is used to interrupt the entire cycle during a packaging cycle. All functions are skipped and the cycle is terminated.

2. On/Off button

Serves to turn the control on or off.

3. Display

The display has four possible modes: See *Figure 2: Possible Display Modes* on page 9 and *Figure 3: Possible Display Modes* on page 9.

- **Start-up mode:** displays the current date and time when starting the machine. It also displays the installed software version. The user cannot take any action.
- **Navigation mode:** displays a program and its functions. The user can navigate through the various programmes and view the current settings of each function.
- **Setting mode:** the user can view and adjust all settings, provided the user is logged in as the owner.
- **Cycle mode:** once the machine starts a packaging cycle, animations of the functions are displayed along with the current value of the function.

4. Cursor keys ▲, ▼, ◀ and ▶

These are used to navigate through the functions. The ▶ button stops the active function and proceeds to the next cycle step. See *Proceeding to the Next Step in the Cycle* on page 9.

5. Enter

This activates/confirms the selected value.

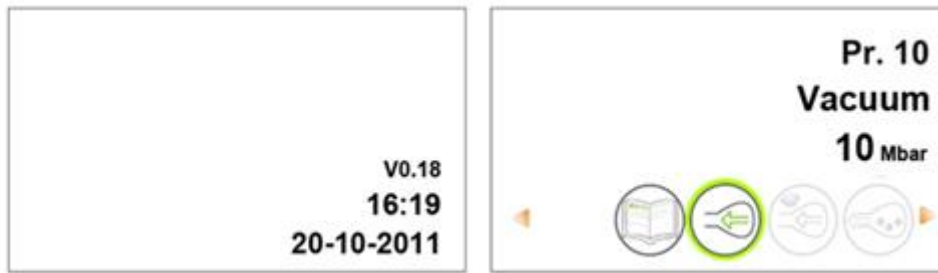

Figure 2: Possible Display Modes

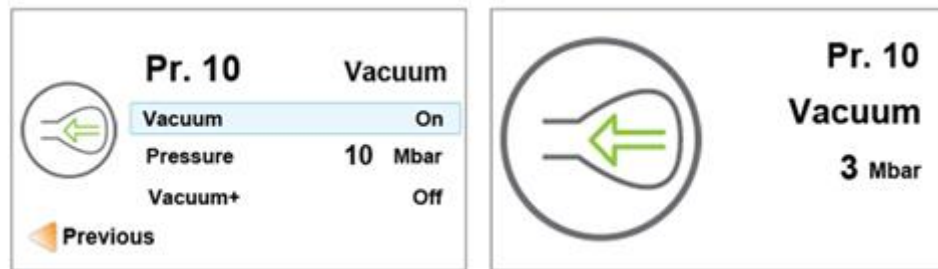

Figure 3: Possible Display Modes

2.2 Proceeding to the Next Step in the Cycle

For some products, it may be necessary to proceed to the next step in the packaging cycle before the vacuum time or the vacuum level has been reached.

Proceed to the next step in the cycle.

Press the ► button.

The next step will be started.

2.3 Changing the ACS Settings

To prevent unauthorised changing of the settings and adjustments, there are different levels of authorisation: user and owner. Authorisation codes for users or owners allow access to the various levels. User access to change the settings of the machine is limited. The default user code is 0000. Users can only activate the printer via the printer icon in the navigation mode.

Owners of the machine are authorised to change the machine settings as well as all function settings. An owner code is requested when the menu icon is selected in navigation mode. This owner code is 1324. When the owner code has been entered, the machine settings menu will be opened. When logged in, the function settings can also be changed. To do so, return to the navigation mode by pressing ◀.



The machine remembers the last authorisation code used, even when the machine has been turned off. Therefore, it may be necessary to manually change the authorisation setting when you are done.

The basic functions below allow you to adjust the machine and/or function settings:

What to do?	Action
Selecting a different setting	Press ▲ or ▼.
Editing the selected setting	Press Enter .
Adjusting a variable	Press ▲ or ▼.
Conforming a variable	Press Enter once the desired variable has been found.
Return to the navigation mode	Press ◀ when all settings have been set to return to the navigation mode.



Figure 4: Overview of the Settings menu on page 11 shows all possible settings for all functions. The Hardware and Service menus are only visible if you have logged in with the Dealer code.

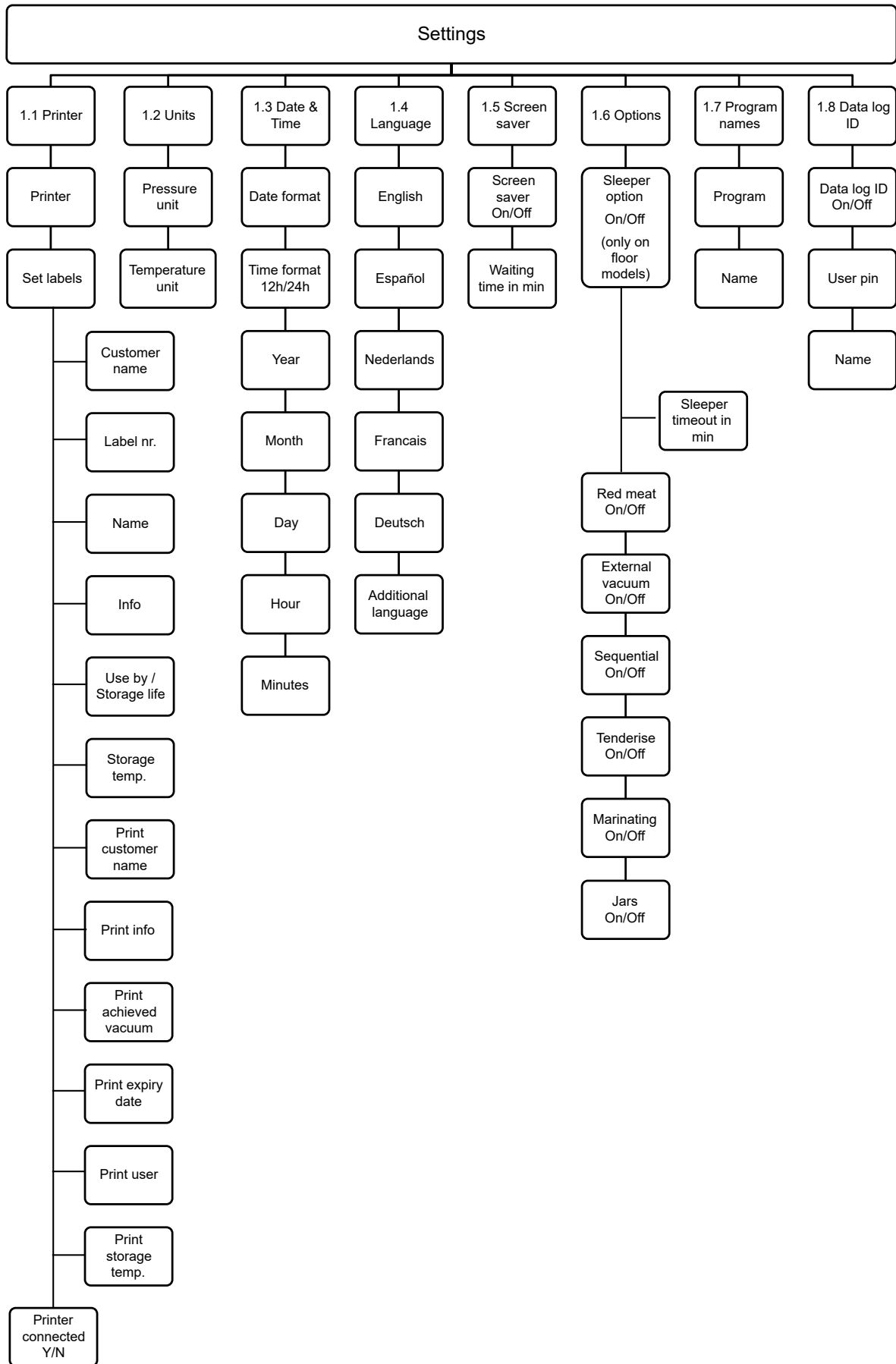

Figure 4: Overview of the Settings menu

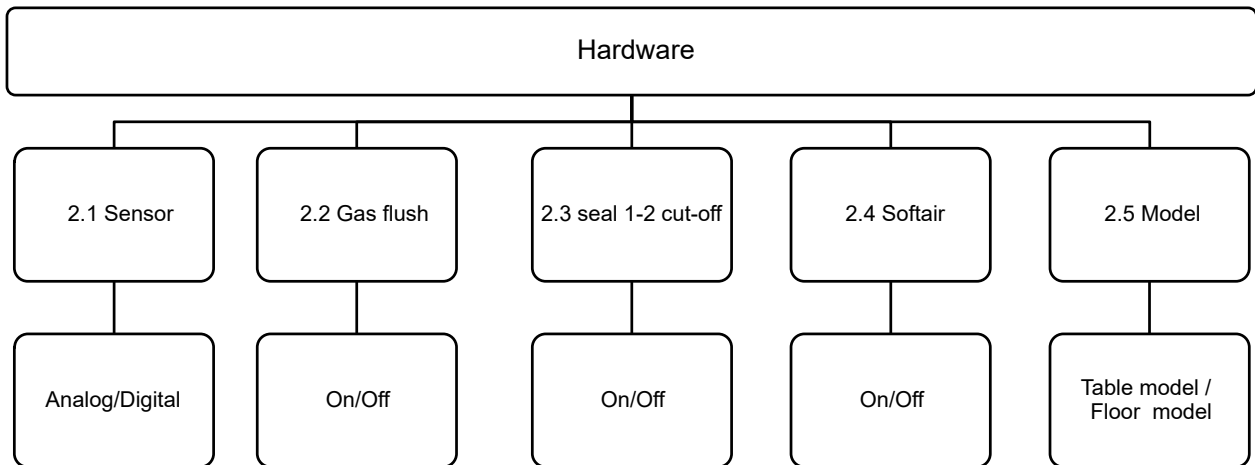

Figure 5: Overview of the Hardware menu

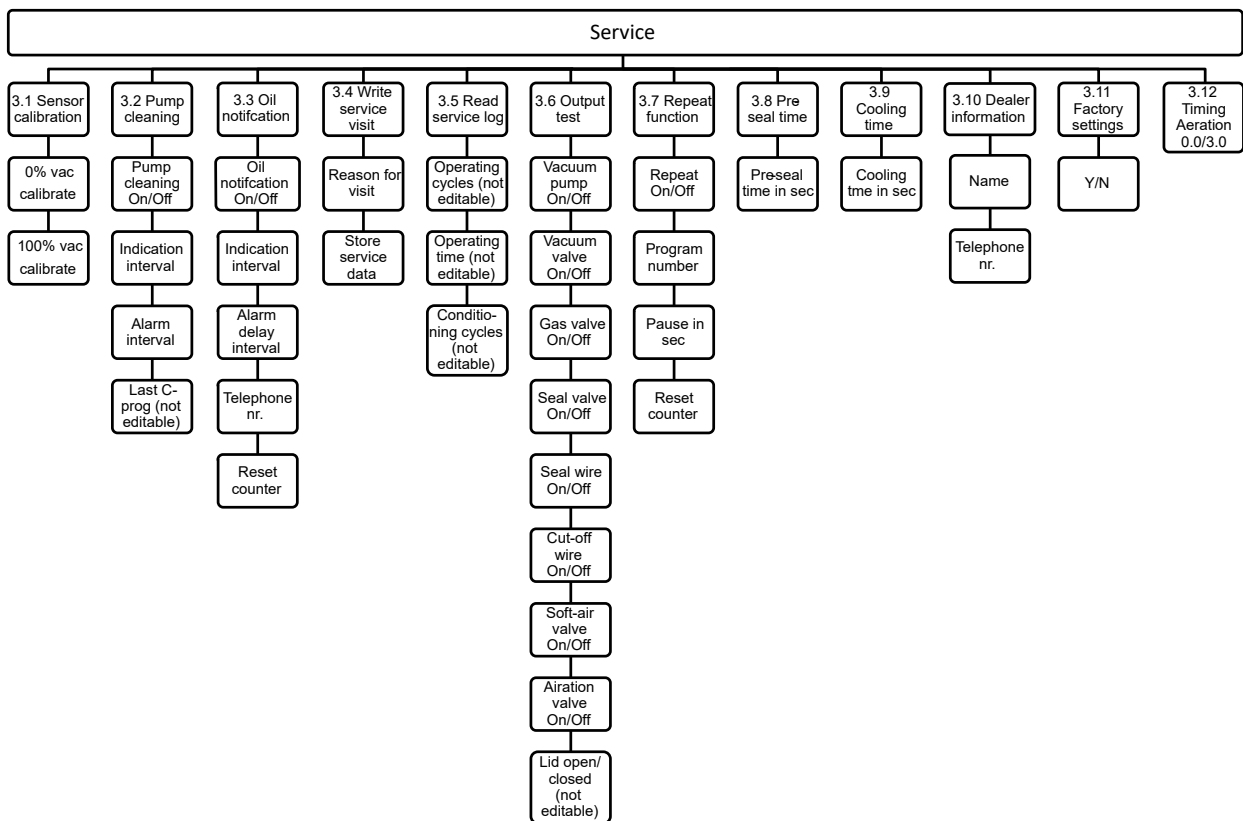

Figure 6: Overview of the Service menu

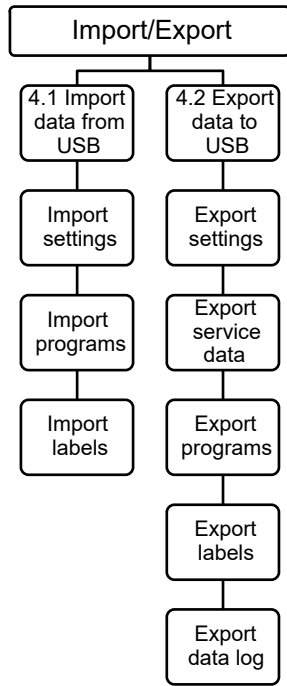

Figure 7: Overview of the Import/Export menu

3 Installation

Consult *Technical Data* on page 35 for the specifications of the machine.



Before installing the machine, carefully read the safety instructions in the User Manual. Failure to follow or disregard of the safety instructions may result in serious injury.

3.1 Transportation and Installation

The machine must be moved and transported in an upright position.

The machine may not be transported using a crane. The machine may be transported with a forklift provided it is still on the pallet packaging.

Moving the machine on wheels on uneven surfaces may lead to loss of stability of the machine. Always move the machine slowly and carefully.

1. Place the machine on a flat, level surface. This is essential to ensure a trouble-free operation of the machine.



Do not position machines with plastic covers in the vicinity of a heat source.



Atmoz, Marlin, Falcon and Polar models: Make sure there is sufficient space (at least 50 cm) around the machine to ensure a proper ventilation.



Boxer, Lynx and Toucan models: Make sure there is sufficient space (at least 15 cm) around the machine to ensure a proper ventilation.

2. Ensure the brakes of the machine are activated.
3. Verify that the machine housing is present and correctly fitted.

If the machine is provided with the optional automatic lid (Polar 2-85 and 2-95 only):

4. Remove the panel door on the right hand side of the machine and release the cable of the foot switch.

3.2 Connecting the Machine



Only a technical expert may perform work on the electrical installation.

Make sure the power supply for this machine matches to the voltage and amperage stated on the machine plate.

Specified amperage: 16 /fuse 20 C	Description
16	Nominal amperage
Fuse 20	Minimum fuse value with the recommended type of fuse
C	C characteristic

1. Fit the correct plug on the cable in accordance with local legislation and connection data. See *Technical Data* on page 35 for the correct electrical connection.
2. Fit the connecting cable to the machine. See *Technical Data* on page 35 for the correct electrical connection.
3. Connect the machine to a grounded wall outlet to avoid fire or electric shock.



- The power cable must be free at all times, and nothing may be placed on it.
- Immediately replace the power cable if damaged.

4. Check the correct direction of rotation of the three-phase model pump. See *Figure 8: Direction of Rotation of the Vacuum Pump* on page 15.

Operating the machine with an incorrect direction of rotation results in damage to the pump, in which case no vacuum can be created. After connecting the machine to a different three-phase power supply, the direction of rotation should be checked again. If the direction of rotation is incorrect, two phases in the plug must be interchanged.

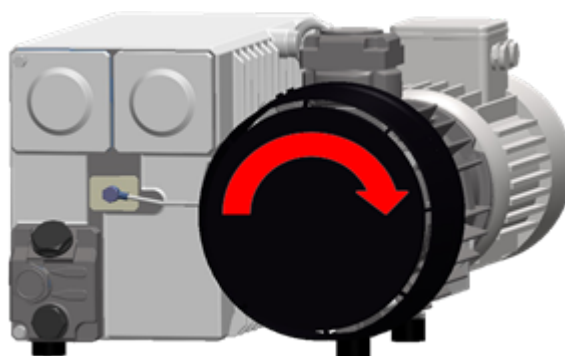

Figure 8: Direction of Rotation of the Vacuum Pump

5. Optional: Connect the gas supply for the gas flush system.
6. Optional: Connect the air supply for additional sealing pressure.

If the Polar is provided with the optional automatic lid (available on models 2-85 and 2-95 only):

7. Connect the hose for compressed air to the hose pillar (8 mm) at the back of the machine. The compressed air is used for the movement of the automatic lid and conveyor and for extra seal pressure.

Pressure	$\geq 6 \text{ bar} - \leq 10 \text{ bar}$
Flow	$\geq 100 \text{ l/min}$



Figure 9: Hose connection for compressed air

3.3 Prior to the First Use

See Vacuum Pump Maintenance in the User Manual for more information how to perform these steps.

Prior to the first use, the following steps must be performed:



Failure to do so may result in unreparable damage to the machine.

1. Check the oil sight glass to see if the amount of oil in the pump is sufficient.
2. Optional: If the amount of oil in the pump is insufficient, refill it.
3. Start up the machine. See the User Manual for more information.

3.4 Removing the Front Panel

You can order the special tools to remove the front panel or carefully use a screwdriver.

To remove the front panel:

1. Put the tools into the slots at the bottom of the front panel.

2. Lift the tools a little and pull them towards you with the control panel.

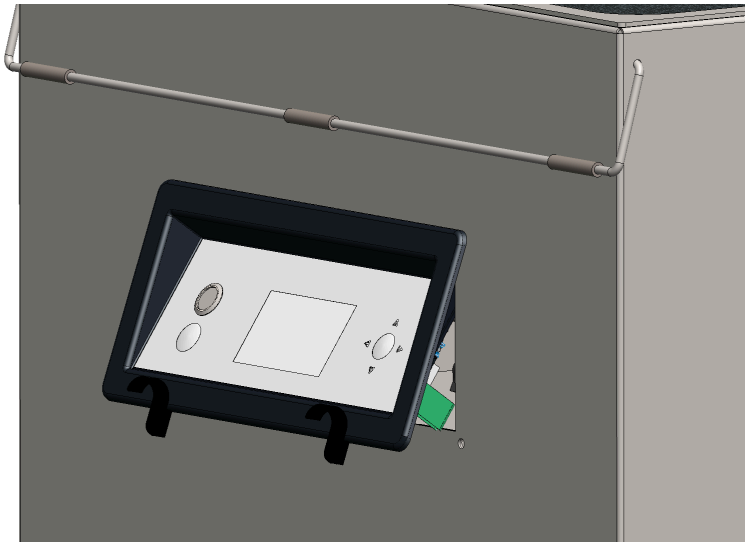

Figure 10: Opening Front Panel floor models

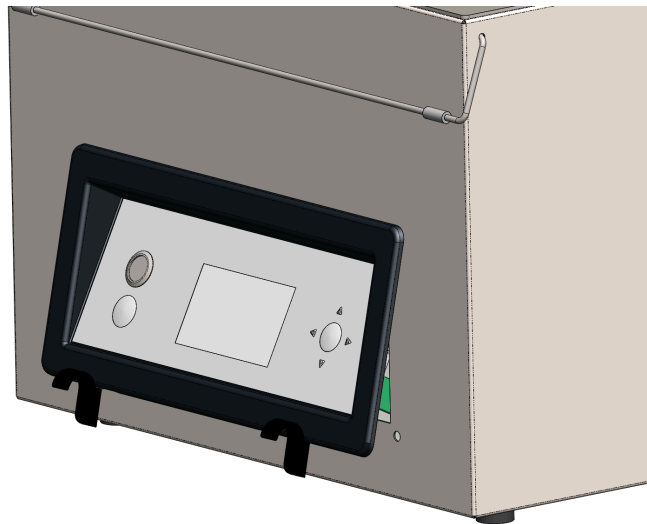

Figure 11: Opening Front Panel table-top models

To place back the front panel:

3. Slide the panel in place at the top.
4. Use the tools to click the panel into place at the bottom.

3.5 Gas

For the protection of the product, it may be desirable to insert a gas into the packaging after vacuuming. Optionally, the machine can be equipped with a gas flush system. The Gas+ option only applies if the machine is equipped with the gas option. For some products it may be desirable to insert additional gas into the packaging to create a "balloon packaging". This allows for a better protection of a fragile product.

The supplier needs to enable the Gas+ option on the machine. See *Gas+ (optional)* on page 18.

Gas types

Packing food	30% CO ₂ and 70% N ₂ (Foodmix)
Packing bread	50% CO ₂ and 50% N ₂
Packing cheese	100% CO ₂
Packing fish	40% CO ₂ and 60% N ₂



Never use a gas mixture containing more than 20% oxygen or other explosive gases. This may cause life-threatening explosions.



Contact your gas supplier for the exact gas to be used for each specific product.

Gas pressure

The maximum gas pressure is 1.0 - 1.5 bar.



When the gas pressure is higher, the gas will blow the bags away from the sealing position.

Bag sizes

To determine the optimum bag size for a product, you need to measure the width and height of the product. Add 2 cm to these dimensions.

The length of the bag should be at least 5 cm longer than the width of the product, but no more than 10 cm to prevent the opening of the bag from falling outside of the chamber.

Recommended capacity reducer unit and hose connector

The reducer should be able to deliver a flow of minimal 60 litres per minute for single chamber machines and 80 litres per minute for double chamber machines.

Filling plates in the cover

Filling plates can be mounted in all Polar double chambers. They fill up the chamber, so there is less air to be transported out. Also the gas consumption is reduced when using the plates.

3.6 Gas+ (optional)

The Gas+ option only applies if the machine is equipped with the gas option. For some products it may be desirable to insert additional gas into the packaging to create a "balloon packaging". This allows for a better protection of a fragile product. The recommended value for Gas+ is 0.7 seconds.

To use the gas flush function, a gas valve needs to be installed in the machine. To enable the Gas flush function, follow the following steps:

1. Open the menu.

2. Enter the dealer code 4753.
3. Go to **Hardware**.
4. Go to **2.2 Gas flush** and set the value to "On".
5. Press the cursor key ◀ to return to the menu.

To set the Gas+ option, follow the steps below:

6. Set the value of Gas. See Gas (optional) in the User Manual.
7. Enable Gas+. Use the cursor keys ▲ and ▼ to go to the value for Gas+ and press **Enter**.
8. Set the desired value using the cursor keys ▲ and ▼ and press **Enter**.
9. Press the cursor key ◀ to return to the menu.
10. Close the lid to start the vacuum cycle.

3.7 Pre-seal and After-seal Settings

The pre-seal and after-seal function is used to change the time settings for pre-seal and after-seal.



Only change these settings after confirmation from Henkelman!

To enter and set the pre-seal and after-seal:

1. Open the menu.
2. Enter the dealer code 4753.
3. Go to **Service**.
4. Go to **3.8 Pre-seal time** or **3.9 Cooling time**.
5. Change the time settings with the ▲ and ▼ buttons.
6. When the settings have been changed, press **Enter** to store them.
7. Press the cursor key ◀ to return to the menu.

3.8 Sleeper settings

If the sleeper option is enabled, the pump will automatically shut off if the machine is not used during a preset period. The pump will automatically start again once a new vacuum cycle is started.

By default, the sleeper option is activated and set to 10 minutes. Follow these steps to change this.

1. Open the menu.
2. Enter the owner code 1324 or the dealer code 4753.
3. Go to **Settings**.
4. Go to **1.6 Options**.
5. Go to **Sleeper option** and set the value to "On".

6. Set the desired value for the sleeper time-out.



The sleeper option cannot be set to less than 1 minute.

7. Press the cursor key ◀ to return to the menu.

4 Maintenance

When carrying out maintenance work, always observe the following safety rules.



- Always disconnect the power supply by turning the main switch to "0" or disconnecting the plug.
- Always disconnect the power supply by disconnecting the plug.
- Always disconnect the air supply (if applicable).



- Only trained technicians are authorised to perform the described maintenance activities.
- Test the machine after carrying out maintenance work or repairs to make sure the machine can be used safely.

4.1 Changing the Program Settings

Users can view the machine programmes and activate the functions in the navigation mode. This is the mode that appears immediately after start-up.

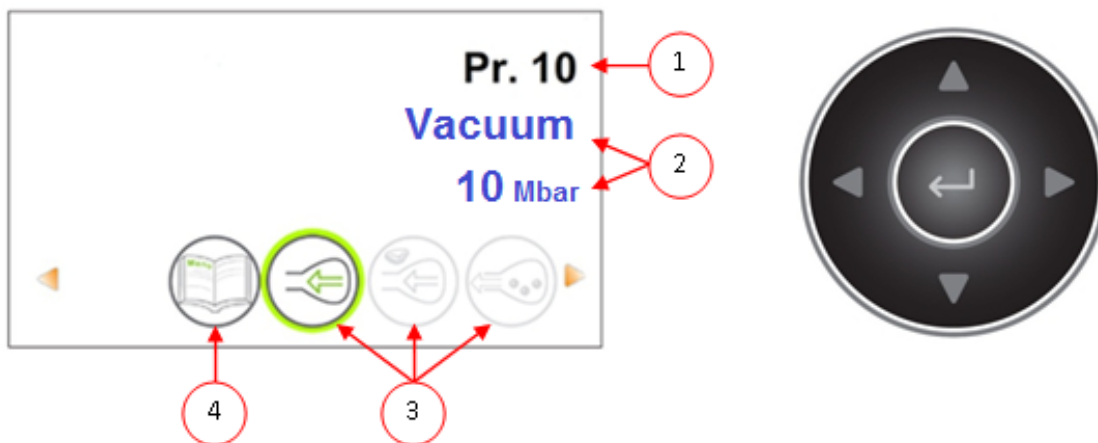

Figure 12: Screen shot of the navigation mode and the operating buttons of the ACS

No.	Element	Explanation
1.	Program number/name	The program shows the currently selected, pre-set program. By switching to a different program, other functions will be activated. The program selection depends on the product being packaged.
2.	Functions	These functions are active or inactive. If a function is active, it is displayed in a blue shade. If a function is inactive, it is displayed in a grey shade.

No.	Element	Explanation
3.	Function active/inactive	The selected function is marked with a green circle. The name and current value of this function will appear on the screen. If the + functions are activated, the + is indicated in colour. If these functions are not active, they are displayed in a grey shade.
4.	Menu	The machine settings can be adjusted via the Menu pictogram at the left of the function overview.

1. Press the ▲ or ▼ buttons to select the desired program.
2. Press the ◀ or ▶ buttons to view the functions.
3. After selecting the desired function, press **Enter** to view and adjust the function settings. Users can view the pre-set configuration and the owner is also authorised to change it.
4. Select the Machine Settings menu and press **Enter** to adjust the machine settings. This menu can only be accessed by the owner. See Guideline for Function Values in the User Manual for the possible limit values of the function values.

4.2 Dealer Information

If dealer information is entered into the machine, this will be displayed on the start-up screen.

1. Open the menu.
2. Enter the dealer code 4753.
3. Go to **Service**.
4. Go to **3.10 Dealer information**.
5. Go to **Name** to enter the dealer name.
The name will only be displayed in the start-up screen if 2 or more characters are entered here.
6. Go to **Telephone nr.** to enter the dealer telephone number.
The telephone number will only be displayed in the start-up screen if 2 or more characters are entered here.
7. Press the cursor key ◀ to return to the menu.

4.3 Machine Counter

The machine counter function registers the operation time of the machine and several functions. This can be used to get information about the state and the use of the machine. The functions that are registered and that the display will show are:

- The total number of cycles that the machine has run.
- The total amount of hours that the pump has run.

- The total number of cycles that the pump conditioning program has run.

To view the machine counter, follow the following steps.

1. Open the menu.
2. Enter the dealer code 4753.
3. Go to **Service**.
4. Go to **3.5 Read service log**.
The values will be shown.
5. Press the cursor key ◀ to return to the menu.

4.4 Setting Service Hour Counter

The service hour counter function is used to set time intervals for regular maintenance purposes on the machine and / or pump.



This function is optional. It is not activated in the standard factory settings.

After expiration of the set time interval, the control panel will show a service message. This means that the interval has expired and maintenance needs to be carried out. The machine will still operate normally but the signal will keep coming back.

To enable and set the Service Hour Counter, follow the following steps.



When service is done on the machine, the counter needs to be reset, so the service hours are set back to 0.

1. Open the menu.
2. Enter the dealer code 4753.
3. Go to **Service**.
4. Go to **3.3 Oil notification**.
5. Enable or disable the **Oil notification**.



If the notification is enabled, a message will appear after the set time, showing service on the machine is needed.

6. Optional: Set the **Indication interval**.

The minimum setting is 1 month, the default setting is 6 months and the maximum setting is 12 months.

When the machine has run for the set hours plus the "alarm hours", a message will appear when the lid is closed.



This means the machine cannot be operated until the service hour counter has been reset!

7. Optional: Add a **Telephone nr.**, so the customer can call the dealer directly.
This telephone number will be shown on the service message.
8. When the settings have been changed, press **Enter** to store them.
9. Press the cursor key ◀ to return to the menu.

4.5 Pump Cleaning Message

On the ACS control, a pump cleaning message can be set. After the set time, the machine will show a message that pump cleaning needs to be performed. You can also set an alarm interval.



If an alarm interval has been set, and the set time plus the alarm interval has expired, the pump cleaning message will only disappear when the pump cleaning program has run completely.

To enable or disable the pump cleaning message, follow the following steps:

1. Open the menu.
2. Enter the dealer code 4753.
3. Go to **Service**.
4. Go to **3.2 Pump cleaning**.
5. Enable or disable the **Pump cleaning**.
6. Optional: When Pump cleaning is enabled, set the **Indication interval**.
The default setting is 100 cycles for table top models and 400 cycles for floor models.
7. Optional: Set the **Alarm interval**.
The default setting is 50 cycles.
The pump cleaning counter is reset when a full pump cleaning program has run.
8. Press the cursor key ◀ to return to the menu.

4.6 Decrease the Cycle Time

The time it takes to complete one cycle can be decreased by shortening the period between sealing and the decompressing phase.

Follow these steps to decrease the cycle time.



This option is only available on table top models.

1. Open the menu.
2. Enter the dealer code **4753**.
3. Go to **Service**.
4. Go to **3.12 Timing Aeration**.

5. Select the preferred reduction setting.

The cycle time can be reduced with 0.1 seconds until a maximum of 3.0 seconds. The default setting is **0.0** (off).

4.7 Maintenance Schedule

The diagram below shows the maintenance activities that must be performed and the interval with which these activities must be performed.

For specific descriptions for performing maintenance activities, consult the appropriate section.

Activity *	1-D	1-W	6-M	1-Y	4-Y
Cleaning					
Cleaning the machine.	X				
Inspections					
Check the oil level.		X			
Run the pump cleaning program.		X			
Inspect the sealing bars.		X			
Inspect the silicone rubber of the silicone holders.		X			
Inspect the lid gasket.		X			
Check the plastic lid for cracks (if applicable).		X			
Inspect the lid springs. Pay additional attention to damage and the fastenings of the lid springs.				X	
Lubrication					
Lubricate the grease nipples of the parallel arms at the pivot point using a food grade grease that is approved by the local authorities.			X		
Replace the oil and the oil filter of the vacuum pump. See <i>Technical Data</i> on page 35 for the type of oil.			X		

Activity *	1-D	1-W	6-M	1-Y	4-Y
Replacement					
Replace the sealing wires.			X		
Replace the silicone rubber of the silicone holders.			X		
Replace the lid gasket.			X		
Replace the oil exhaust filter.				X	
Replace the oil filter.				X	
Contact your dealer for professional servicing.				X	
Replace the plastic lid (if applicable).					X

* 1-D = Daily, 1-W = Weekly, 6-M = Every 6 months, 1-Y = Annually, 4-Y = Every 4 years

5 Troubleshooting and Error Codes

The tables below show the possible malfunctions and the corresponding causes as well as the steps to be taken.

Malfunction	Activity	More information
Control panel does not illuminate.	<ul style="list-style-type: none">• Connect the machine to the power supply.• Check the machine/circuit breaker.• Check or replace the fuse of the control transformer.	<i>Electrical Installation</i> on page 44.
The control panel is on, but there is no activity after closing the lid.	<ul style="list-style-type: none">• Check or adjust the switch of the lid.• Check or replace the fuse of the control transformer.• Check/replace the circuit board fuse.	

Malfunction	Activity	More information
Insufficient end vacuum.	<ul style="list-style-type: none"> • Check the vacuum settings of the program and adjust them. • Make sure that the extraction opening is not covered. • Check the oil level in the pump. • Check/replace the oil exhaust filter. • Check/replace the lid gasket. 	<p>Operation in the User Manual.</p> <p>Vacuum Pump in the User Manual.</p> <p>Replacing the Oil Exhaust Filter in the User Manual.</p> <p>Replacing the Lid Gasket in the User Manual.</p>
Vacuum process is slow.	<ul style="list-style-type: none"> • Make sure that the extraction opening is not covered. • Check the oil level in the pump. • Check/replace the oil exhaust filter. 	<p>Vacuum Pump in the User Manual.</p> <p>Replacing the Oil Exhaust Filter in the User Manual..</p>

Malfunction	Activity	More information
Vacuum bag is not sealed correctly.	<ul style="list-style-type: none"> • Check the seal settings of the program and adjust them. • Check/replace the Teflon tape and the sealing wires. • Check/replace the silicone rubber of the silicone holders. • Check the inside of the vacuum for contamination and clean it. • Decrease the setting for gas flush (if activated). 	<p>Operation in the User Manual.</p> <p>Replacing the Sealing Wire in the User Manual.</p> <p>Replacing the Silicone Rubber of the Silicone Holders in the User Manual.</p>

The lid does not open automatically.	<ul style="list-style-type: none"> • Check the gas spring/ springs of the lid. 	Contact your supplier.
--------------------------------------	-----------------------------------------------------------------------------------------------	------------------------

Error messages for the ACS

Malfunction	Activity	More information
Message "Sensor missing" in display.	<ul style="list-style-type: none"> • Check whether the sensor is connected. 	
Message "Cycle aborted" in display.	<ul style="list-style-type: none"> • Check whether the lid is open. 	

Malfunction	Activity	More information
Message “Pump cleaning” in display.	<ul style="list-style-type: none"> Close the lid to run the pump cleaning program. 	<ul style="list-style-type: none"> See Vacuum Pump maintenance in the User Manual. To ignore / postpone the message: press the STOP button. To change the number of cycles after which the message appears, see <i>Pump Cleaning Message</i> on page 24.
Message “Please inspect oil level and quality” in display.	<ul style="list-style-type: none"> Replace the oil and filter of the vacuum pump. 	<ul style="list-style-type: none"> See Vacuum Pump maintenance in the User Manual. To ignore / postpone the message: press the STOP button. To reset the message, see <i>Setting Service Hour Counter</i> on page 23.

5.1 Using Output Test

A step-by-step cycle test can be done using the output test mode. Each switch, valve or relay can be individually be tested to make troubleshooting easier.

The first function that can be tested is the vacuum pump. If activated, the pump will start running and after closing the lid a vacuum will be created. If the vacuum pump is deactivated, the lid will be held closed by the remaining vacuum under the lid. This remaining vacuum is necessary to test other vacuum related functions such as sealing, soft-air and aeration.

During activation of the seal valve, air will enter through the sealing valve to lift the sealing bar up. If the sealing system is in good condition, air will only enter for a short period of time. If air continues to flow, there must be a leak somewhere in the sealing system.

In the same analogue the other functions can be tested.

The output test function is used to verify the operation of the machine functions. In case of a machine malfunction, it is possible to test the different functions of the packaging cycle separately to analyse the problem.

To activate and use the output test, follow the following steps. This makes it possible to check the electrical circuits, from the membrane panel, through the electrical connections and wiring up to the actual component. To check the actual functioning of each individual component, see *Checking Functioning of Individual Components* on page 31.

1. Open the menu.
2. Enter the dealer code 4753.
3. Go to **Service**.
4. Go to **3.6 Output test**.
5. Select the necessary outputs and enable them.
6. Press the cursor key ◀ to return to the menu.

5.2 Checking Functioning of Individual Components

To check the actual functioning of each individual component, follow these steps.

- **Pump**

Activate "gate" 1. This will activate the pump and the pump will start running. When the lid is closed, while the pump is running, a vacuum will be achieved inside the chamber.



This is only the case with table top models.

- **Vacuum valve**

Activate "gate" 2. If only the vacuum valve is activated, a "click" can be heard. However, if multiple "gates" are activated at the same time, the actual function can be tested. If you first activate the pump (as described above) the pump will start running, but a vacuum will only be created at the pump side of the vacuum valve. When the lid is closed nothing will change. Before a vacuum can be created in the vacuum chamber, the vacuum valve has to be opened. For this it is necessary to activate "gate" 2. Now a loud air flow can be heard. This as a clear indication the vacuum valve is opened. If the lid is closed now, a vacuum will be achieved inside the chamber. Deactivating "gate" 2 will stop the evacuating of air inside the chamber. The pressure will no longer drop.



This is only the case with floor models.

- **Gas valve**



If a gas bottle is connected, the valve on the bottle should be opened.

Activate "gate" 3. This will electrically activate the gas valve and gas will flow out of the gas nozzles. If the lid is closed and a vacuum was created, the vacuum level will drop due to the gas that flows in.

- **Seal valve**



For testing the seal valve and the seal cylinders operation, it is necessary to create a vacuum inside the chamber.

Activate "gate" 4. This will allow air to flow into the lower compartment of the cylinders and will move the cylinder up. The cylinders will lift up the seal bar until it touches the final position against the silicone holders. Deactivating "gate" 4 will result in the seal bar to move back to its original position.



If the sealing system is in good condition, air will only enter for a short period of time. If air continues to flow, there must be a leak somewhere in the sealing system.

- **Seal relay 1**



During this test the seal bar will be heated up, activating it too long can result in burning the Teflon tape. It is recommended to activate this function for max. 1 to 2 seconds.

Activate "gate" 5. This will activate the seal relay and the seal bar will heat up. This test can be done while the lid is open. By touching the seal bar it is possible to check if the seal bar is heated.



The seal bar can be very warm.



To prevent the seal bar from burning completely, a time-out function is integrated. After three seconds the seal relays are automatically deactivated.

- **Seal relay 2**



During this test the seal bar will be heated up, activating it too long can result in burning the Teflon tape. It is recommended to activate this function for max. 1 to 2 seconds.

Activate "gate" 6. This will activate a second seal relay in case the machine is equipped with a seal 1-2 option. When the machine is equipped with this option, "Gate" 5 will activate seal relay 1 which results in heating only the seal wire. "Gate" 6 will activate seal relay 2 and results in heating only the cut-off wire. This test can be done while the lid is open. By touching the seal bar it is possible to check if the seal wire and / or cutting wire is heated.



The seal bar can be very warm.



To prevent the seal bar from burning completely, a time-out function is integrated. After three seconds the seal relays are automatically deactivated.

- **Soft air valve**

Activate "gate" 7; This will electrically activate the soft-air valve, which allows a small amount of outside air to flow inside the chamber. For this, it is necessary that there is a pressure difference. First, create a vacuum inside the chamber as described in the part "Pump". If the soft-air valve is activated and there is a vacuum inside the chamber, the vacuum level will drop slowly due to the outside air that flows in.

- **Decompression valve**

Activate "gate" 8. This will electrically activate the decompression valve, which allows outside air to flow inside the chamber. For this, it is necessary that there is a pressure difference. First, create a vacuum inside the chamber as described in the part "Pump". If the decompression valve is activated and there is a vacuum inside the chamber, the vacuum level will drop rapidly due to the outside air that flows in.

5.3 Resetting Factory Settings

The factory settings function is used to return all values and settings (operation mode and service mode) of the machine to the original factory settings.

To reset the factory settings, follow the following steps.

1. Open the menu.
2. Enter the dealer code 4753.
3. Go to **Service**.
4. Go to **3.11 Factory settings**.

5. Select **Yes** to reset the factory settings.

All values and settings will be reset to the factory settings.



The machine counter values (see *Machine Counter* on page 22) will not be reset.

6. Press the cursor key ◀ to return to the menu.

5.4 Calibrating the Sensor

The sensor calibration function is used to set the right pressure values to the corresponding vacuum percentage values.



This calibration procedure applies to the regular sensor control system, not to the Liquid (H₂O) Control system. The Liquid (H₂O) Control sensor is already calibrated in the factory and cannot be re-calibrated.

Before calibrating, ensure that the tubing to the sensor is clean and dry. Ensure that the required vacuum measurement tool is accurate to 99.8% (2 mbar). If your measurement tool does not meet this standard, it is not recommended to proceed. It could make the situation worse.

Two values should be calibrated

- No vacuum (normal atmospheric pressure)
- The deepest possible vacuum

To calibrate the sensor, follow the following steps.

1. Make sure the lid is open
2. Select the 0% field and press enter to activate it.
3. Use the ▲ and ▼ buttons to set the atmospheric value.
4. Select the 100% field and press enter to activate it.
5. Position the vacuum measuring device inside the chamber and close the lid.
6. Once the vacuum level has reached the deepest value (99.8% = 2 mbar), push the ▲ and ▼ buttons to set the lowest vacuum value.

6 Appendices

6.1 Technical Data

6.1.1 Marlin series

Marlin	52	90
General		
Ambient temperature during operation	5 to 30°C	5 to 30°C
Machine working conditions: relative humidity (non-condensing)	10-90%	10-90%
Sound emission	< 70 dB(A)	< 70 dB(A)
Maximum daily production	8 hrs/day	8 hrs/day
Dimensions of the machine		
Width	695 mm	1066 mm
Length	710 mm	480 mm
Height	1025 mm	970 mm
Weight	143 kg	142 kg
Maximum product height	200 mm	100 mm
Gas flush system (optional)		
Dimensions connector	6 mm	6 mm
Gas supply	60-100 l/min	60-100 l/min
Maximum supply pressure	1 bar	1 bar
Electrical connection		
Supply voltage	*	*
Connected load	*	*
Vacuum pump		
Capacity	63 m ³ /h	63 m ³ /h
Oil	1 litre	1 litre
Type of synthetic oil	VS100	VS100
Ambient temperature synthetic oil	-10 to 40°C**	-10 to 40°C**

*See machine plate.

**For different temperatures, please contact your dealer.

6.1.2 Falcon series

Falcon	52	80	2-60	2-70
General				
Ambient temperature during operation	5 to 30°C	5 to 30°C	5 to 30°C	5 to 30°C
Machine working conditions: relative humidity (non-condensing)	10-90%	10-90%	10-90%	10-90%
Sound emission	< 70 dB(A)	< 70 dB(A)	< 70 dB(A)	< 70 dB(A)
Maximum daily production	8 hrs/day	8 hrs/day	8 hrs/day	8 hrs/day
Dimensions of the machine				
Width	682 mm	900 mm	1060 mm	1260 mm
Length	695 mm	820 mm	900 mm	1020 mm
Height	1060 mm	1050 mm	1179 mm	1185 mm
Weight	163 kg	227 kg	236 kg	319 kg
Maximum product height	235 mm	235 mm	235 mm	235 mm
Sealing pressure (optional)				
Dimensions hose connector	8 mm	8 mm	8 mm	8 mm
Maximum supply pressure	1 bar	1 bar	1 bar	1 bar
Maximum air consumption	1 l/cycle	3 l/cycle	1 l/cycle	1 l/cycle
Gas flush system (optional)				
Dimensions connector	6 mm	6 mm	6 mm	6 mm
Gas supply	60-100 l/min	60-100 l/min	60-100 l/min	60-100 l/min
Maximum supply pressure	1 bar	1 bar	1 bar	1 bar
Electrical connection				
Supply voltage	*	*	*	*
Connected load	*	*	*	*
Vacuum pump				
Capacity	63 m ³ /h	100 m ³ /h	63 m ³ /h	100 m ³ /h
Oil	1 litre	2 litres	1 litre	2 litres
Type of synthetic oil	VS100	VS100	VS100	VS100
Ambient temperature synthetic oil	-10 to 40°C**	-10 to 40°C**	-10 to 40°C**	-10 to 40°C**

6.1.3 Polar series

Polar	52	80	110	2-40
General				
Ambient temperature during operation	5 to 30°C	5 to 30°C	5 to 30°C	5 to 30°C
Machine working conditions: relative humidity (non-condensing)	10-90%	10-90%	10-90%	10-90%
Sound emission	< 70 dB(A)	< 70 dB(A)	< 70 dB(A)	< 70 dB(A)
Maximum daily production	8 hrs/day	8 hrs/day	8 hrs/day	8 hrs/day
Dimensions of the machine				
Width	700 mm	900 mm	1200 mm	1400 mm
Length	740 mm	790 mm	880 mm	820 mm
Height	1100 mm	1100 mm	1125 mm	1325 mm
Weight	183 kg	241 kg	390 kg	310 kg
Maximum product height				
	200 mm	200 mm	270 mm	240 mm
Sealing pressure (optional)				
Dimensions hose connector	8 mm	8 mm	8 mm	8 mm
Maximum supply pressure	1 bar	1 bar	1 bar	1 bar
Maximum air consumption	1 l/cycle	3 l/cycle	3 l/cycle	2.5 l/cycle
Gas flush system (optional)				
Dimensions connector	6 mm	6 mm	6 mm	6 mm
Gas supply	60-100 l/min	60-100 l/min	60-100 l/min	60-100 l/min
Maximum supply pressure	1 bar	1 bar	1 bar	1 bar
Electrical connection				
Supply voltage	*	*	*	*
Connected load	*	*	*	*
Vacuum pump				
Capacity	63 m ³ /h	100 m ³ /h	100/160/300 m ³ /h	63 m ³ /h
Oil	1 litre	2 litres	2/5/6.5 litres	1 litre
Type of synthetic oil	VS100	VS100	VS100	VS100
Ambient temperature synthetic oil	-10 to 40°C**	-10 to 40°C**	-10 to 40°C**	-10 to 40°C**

Polar	2-50	2-75	2-85	2-95
General				
Ambient temperature during operation	5 to 30°C	5 to 30°C	5 to 30°C	5 to 30°C
Machine working conditions: relative humidity (non-condensing)	10-90%	10-90%	10-90%	10-90%
Sound emission	< 70 dB(A)	< 70 dB(A)	< 70 dB(A)	< 70 dB(A)
Maximum daily production	8 hrs/day	8 hrs/day	8 hrs/day	8 hrs/day
Dimensions of the machine				
Width	1400 mm	1490 mm	1900 mm	2425 mm
Length	920 mm	1220 mm	1295 mm	1240 mm
Height	1325 mm	1344 mm	1450 mm	1607 mm
Weight	345 kg	537 kg	685 kg	767 kg
Maximum product height	240 mm	250 mm	255/300 mm*	280 mm
Sealing pressure (optional)				
Dimensions hose connector	8 mm	8 mm	8 mm	8 mm
Maximum supply pressure	1 bar	1 bar	1 bar	1 bar
Maximum air consumption	2.5 l/cycle	3 l/cycle	3 l/cycle	4.5 l/cycle
Gas flush system (optional)				
Dimensions connector	6 mm	6 mm	6 mm	6 mm
Gas supply	60-100 l/min	60-100 l/min	60-100 l/min	60-100 l/min
Maximum supply pressure	1 bar	1 bar	1 bar	1 bar
Electrical connection				
Supply voltage	*	*	*	*
Connected load	*	*	*	*
Vacuum pump				
Capacity	100 m ³ /h	160 m ³ /h	300 m ³ /h	300 m ³ /h
Oil	2 litres	5 litres	6.5 litres	6.5 litres
Type of synthetic oil	VS100	VS100	VS100	VS100
Ambient temperature synthetic oil	-10 to 40°C**	-10 to 40°C**	-10 to 40°C**	-10 to 40°C**

*See machine plate.

**For different temperatures, please contact your dealer.

6.1.4 Boxer series

Boxer	30	35	42
General			
Ambient temperature during operation	5 to 30°C	5 to 30°C	5 to 30°C
Machine working conditions: relative humidity (non-condensing)	10-90%	10-90%	10-90%
Sound emission	< 70 dB(A)	< 70 dB(A)	< 70 dB(A)
Maximum daily production	5 hrs/day	5 hrs/day	5 hrs/day
Dimensions of the machine			
Width	450 mm	450 mm	493 mm
Length	554 mm	554 mm	528 mm
Height	405 mm	405 mm	440 mm
Weight	46 kg	49 kg	62 kg
Maximum product height	150 mm	150 mm	180 mm
Gas flush system (optional)			
Dimensions connector	6 mm	6 mm	6 mm
Gas supply	60-100 l/min	60-100 l/min	60-100 l/min
Maximum supply pressure	1 bar	1 bar	1 bar
Electrical connection			
Supply voltage	*	*	*
Connected load	*	*	*
Vacuum pump			
Capacity	8 m ³ /h	16 m ³ /h	21 m ³ /h
Oil	0.25 litre	0.3 litre	0.5 litre
Type of synthetic oil	VS32	VS32	VS32
Ambient temperature synthetic oil	-10 to 40°C**	-10 to 40°C**	-10 to 40°C**

*See machine plate.

**For different temperatures, please contact your dealer.

Boxer	42XL	42XL BA	52
General			
Ambient temperature during operation	5 to 30°C	5 to 30°C	5 to 30°C
Machine working conditions: relative humidity (non-condensing)	10-90%	10-90%	10-90%
Sound emission	< 70 dB(A)	< 70 dB(A)	< 70 dB(A)
Maximum daily production	5 hrs/day	5 hrs/day	5 hrs/day
Dimensions of the machine			
Width	493 mm	403 mm	698 mm
Length	616 mm	616 mm	528 mm
Height	470 mm	420 mm	440 mm
Weight	67 kg	67 kg	66 kg
Maximum product height	180 mm	120 mm	185 mm
Gas flush system (optional)			
Dimensions connector	6 mm	6 mm	6 mm
Gas supply	60-100 l/min	60-100 l/min	60-100 l/min
Maximum supply pressure	1 bar	1 bar	1 bar
Electrical connection			
Supply voltage	*	*	*
Connected load	*	*	*
Vacuum pump			
Capacity	21 m ³ /h	21 m ³ /h	21 m ³ /h
Oil	0.5 litre	0.5 litre	0.5 litre
Type of synthetic oil	VS32	VS32	VS32
Ambient temperature synthetic oil	-10 to 40°C**	-10 to 40°C**	-10 to 40°C**

*See machine plate.

**For different temperatures, please contact your dealer.

6.1.5 Lynx series

Lynx	32	42
General		
Ambient temperature during operation	5 to 30°C	5 to 30°C
Machine working conditions: relative humidity (non-condensing)	10-90%	10-90%
Sound emission	< 70 dB(A)	< 70 dB(A)
Maximum daily production	5 hrs/day	5 hrs/day
Dimensions of the machine		
Width	534 mm	534 mm
Length	400 mm	491 mm
Height	385 mm	396 mm
Weight	35 kg	46 kg
Maximum product height	103 mm	114 mm
Gas flush system (optional)		
Dimensions connector	6 mm	6 mm
Gas supply	60-100 l/min	60-100 l/min
Maximum supply pressure	1 bar	1 bar
Electrical connection		
Supply voltage	*	*
Connected load	*	*
Vacuum pump		
Capacity	8 m ³ /h	16 m ³ /h
Oil	0.25 litre	0.3 litre
Type of synthetic oil	VS32	VS32
Ambient temperature synthetic oil	-10 to 40°C**	-10 to 40°C**

*See machine plate.

**For different temperatures, please contact your dealer.

6.1.6 Toucan series

	Toucan 42 Regular	Toucan 42 Square
General		
Ambient temperature during operation	5 to 30°C	5 to 30°C
Machine working conditions: relative humidity (non-condensing)	10-90%	10-90%
Sound emission	< 70 dB(A)	< 70 dB(A)
Maximum daily production	5 hrs/day	5 hrs/day
Dimensions of the machine		
Width	480 mm	480 mm
Length	581 mm	581 mm
Height	795 mm	795 mm
Weight	108 kg	108 kg
Maximum product height	275 mm	330 mm
Gas flush system (optional)		
Dimensions connector	6 mm	6 mm
Gas supply	60-100 l/min	60-100 l/min
Maximum supply pressure	1 bar	1 bar
Electrical connection		
Supply voltage	*	*
Connected load	*	*
Vacuum pump		
Capacity	21 m ³ /h	21 m ³ /h
Oil	0.5 litre	0.5 litre
Type of synthetic oil	VS32	VS32
Ambient temperature synthetic oil	-10 to 40°C**	-10 to 40°C**

*See machine plate.

**For different temperatures, please contact your dealer.

6.1.7 Atmoz series

	Atmoz 90	Atmoz 2-75	Atmoz 2-90
General			
Ambient temperature during operation	5 to 30°C	5 to 30°C	5 to 30°C
Sound emission	< 70 dB(A)	< 70 dB(A)	< 70 dB(A)
Maximum daily production	8 hrs/day	8 hrs/day	8 hrs/day
Dimensions of the machine			
Width	980 mm	1545 mm	1965 mm
Length	1030 mm	1211 mm	1320 mm
Height	1114 mm	1106 mm	1106 mm
Weight	345 kg	462 kg	770 kg
Maximum product height	280 mm	280 mm	280 mm
Sealing pressure (optional)			
Connection size	6 mm	8 mm	8 mm
Maximum supply pressure	1 bar	1 bar	1 bar
Gas flush system (optional)			
Dimensions connector	8 mm	13 mm	13 mm
Gas supply	60-100 l/min	60-100 l/min	60-100 l/min
Maximum supply pressure	1 bar	1 bar	1 bar
Electrical connection			
Tension	* V	* V	* V
Power	* kW	* kW	* kW
Vacuum pump			
Capacity	100 m ³ /h	160 m ³ /h	300 m ³ /h
Oil	2.0 litre	5.0 litre	6.5 litre
Oil type	VS 100	VS 100	VS 100
Ambient temperature synthetic oil	-10 to 40°C**	-10 to 40°C**	-10 to 40°C**

*See machine plate.

**For different temperatures, please contact your dealer.

6.2 Electrical Installation

The electrical installation provides power for the vacuum pump, the seal system and the operation of the machine.

See the electrical diagram for the further structure and operation of the electrical installation. Please contact your supplier for the electrical diagram.



Only a technical expert may perform work on the electrical installation.

Atmoz

The machines consists of the following electrical components:

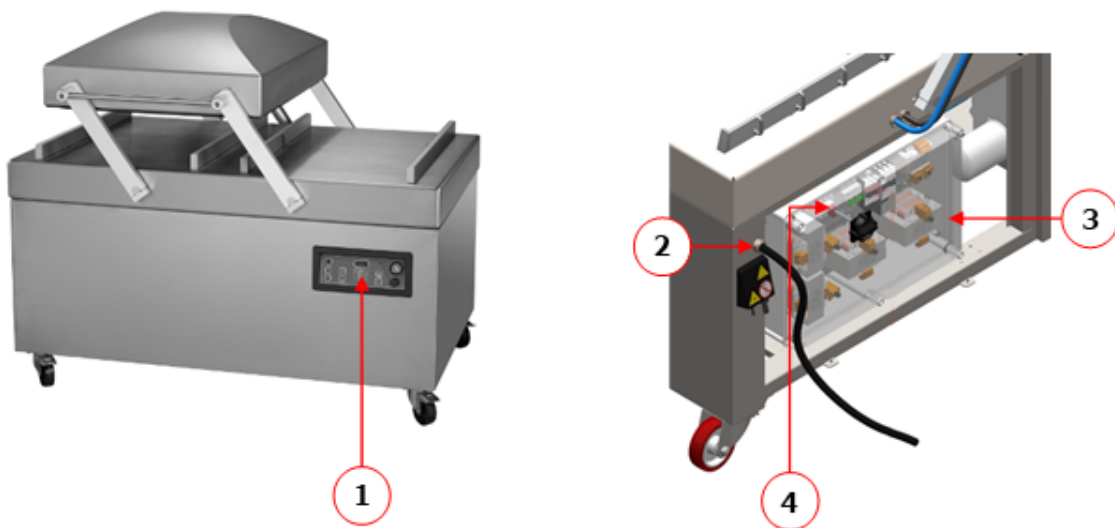

Figure 13: Overview of the Electrical Installation

- 1. Control panel**
This serves to operate the control functions.
- 2. Power connection**
This serves to connect the machine to the power supply.
- 3. Control box**
This serves the control components operate the control functions. It also houses the circuit breaker
- 4. Main switch**
This switch is used to switch the machine ON and OFF.

Marlin, Falcon and Polar

The machine consists of the following electrical components:

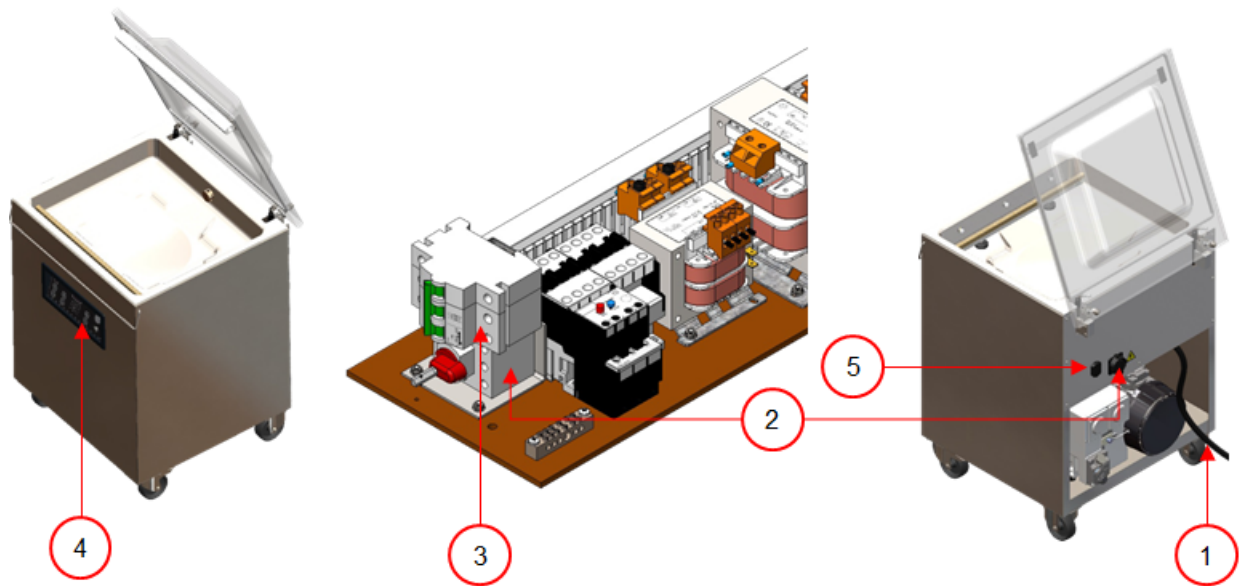

Figure 14: Overview of the Electrical Installation, Marlin

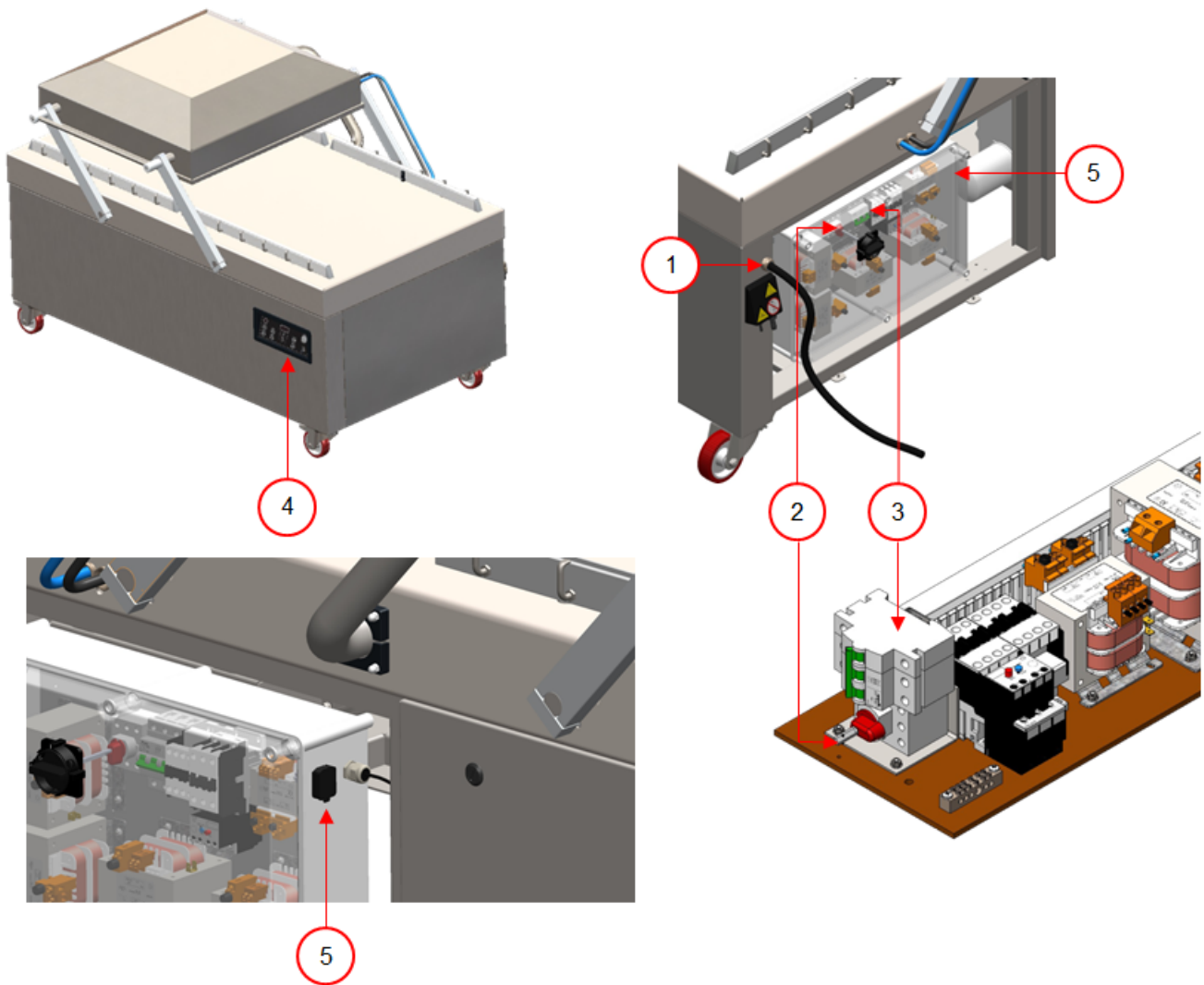

Figure 15: Overview of the Electrical Installation,

1. Power connection and cable

This serves to connect the machine to the power supply. The machine is supplied without an electrical plug.

2. Main switch

This switch is used to switch the machine ON and OFF.

3. Circuit breaker

Protects against overload or a short circuit.

4. Control panel

This serves to operate the control functions. Depending on your model, your machine will have one of the following control options:

- Operating Elements in the User Manual

5. USB connector (only in case of ACS control)

The USB connector is located on the side of the control box, which is located behind the rear wall. Reaching the USB connector requires removing the rear wall.



After opening the cover of the USB connector, the machine is no longer waterproof (IP65).

The USB connector enables the import and export of data.

Boxer, Lynx, NEO, Toucan

The machine consists of the following electrical components:

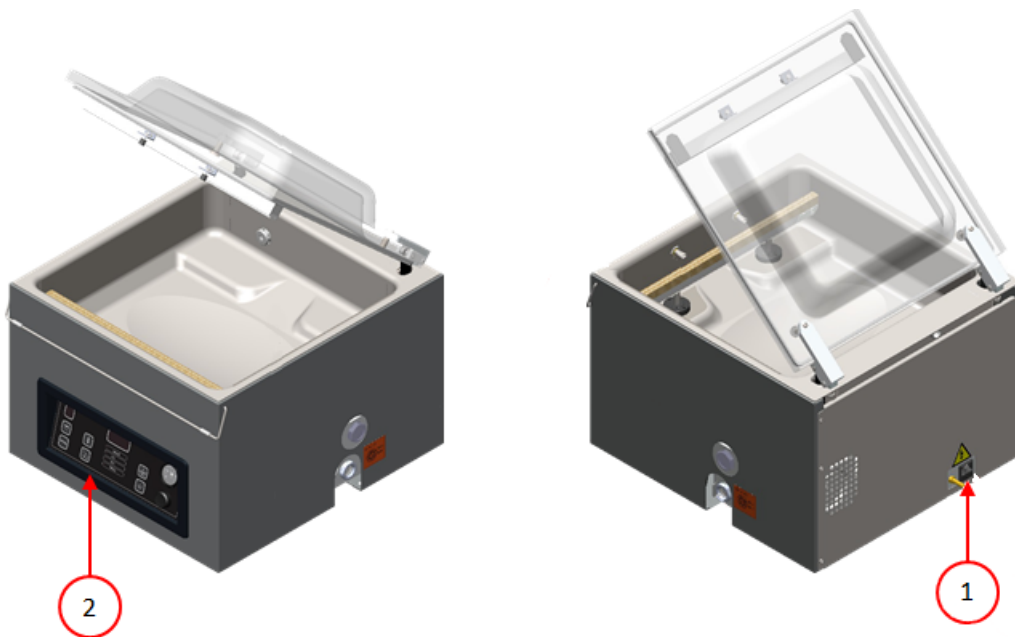

Figure 16: Overview of the Electrical Installation

1. Power connection

This serves to connect the machine to the power supply.

2. Control panel

This serves to operate the control functions. Depending on your model, your machine will have one of the following control options:

- Operating Elements in the User Manual

3. USB connector

The USB connector is located on the side or the rear of the machine. Reaching the USB connector requires removing the rear wall.

The USB connector enables the import and export of data.



Henkelman BV
Titaniumlaan 10
5221 CK 's-Hertogenbosch
+31 (0)73 621 3671
+31 (0)73 622 1318
www.henkelman.com
info@henkelman.com